

Manual

Basic Line

TV 44 & TV 59

River Line

TV 43 & TV 58

English

IV / 2008

Contents

1 The digital satellite tracking system.....	4
1.1 EPAK®-TV system overview.....	4
1.2 Safety recommendations.....	5
2 Installation.....	6
2.1 Standard delivery.....	6
2.2 Installation overview.....	6
2.3 Selecting location.....	6
2.4 Mounting surface.....	7
2.5 Planning the cable paths.....	7
2.6 Power supply.....	8
2.7 Drillings.....	8
2.8 Mounting the antenna unit.....	9
2.9 System cable connections.....	9
3 Control elements.....	10
3.1 Control unit.....	10
3.2 Preparing the receiver.....	11
3.3 Power on / off / Standby.....	11
3.4 Password access to Setup menu.....	11
3.5 Adjusting the Setup parameters.....	12
4 TV operation.....	13
4.1 Stopping the Tracking function in harbours.....	14
5 Satellites.....	15
5.1 Adding new satellites.....	15
5.2 Update of satellite data base.....	17
5.3 Delete stored data.....	17
5.4 Selection of stored satellites.....	18
5.4.1 Automatic selection of satellites.....	18
5.4.2 Manual selection of satellites.....	18
6 Miscellaneous.....	19
6.1 Compass calibration.....	19
6.2 Adjustment of the LNB type.....	19
6.3 Special functions via the Standby mode.....	20
6.4 Fastscan function (US only).....	20
7 APPENDICES.....	21
7.1 Maintenance.....	21
7.2 Overview of menu structure.....	22
7.3 Fehlermeldungen.....	23
7.4 Replaceable parts.....	25
7.5 Optional parts.....	25

7.6 System overview.....	25
7.6.1 General cable data.....	25
7.6.2 Single User on Single EU Antenna.....	26
7.6.3 Multi Users on Single EU Antenna.....	27
7.6.4 Two Users on Twin EU Antenna.....	28
7.6.5 Multi Users on Twin EU Antenna.....	29
7.6.6 Multi Users on Quattro EU Antenna.....	30
7.7 Elevation angles.....	31
7.8 Technical specifications.....	33

1 The digital satellite tracking system

The advanced technologies of the satellite tracking system EPAK-TV makes an excellent television reception possible. An 360° high-speed tracking guarantees a non-stop reception of your favourite channels even during your trip in open seas. Once the connection to a satellite is established, the tracking system will stay connected to that satellite even in the roughest sea conditions.

The EPAK-TV system is suitable for vessels of any size including smaller boats of less than 36ft (11m). According to different tracking conditions of the respective region there is a choice between a reflector antenna dish of 18" (45cm) and 23.6" (60cm) in diameter. The antenna is capable of tracking horizontally and vertically due to its direct servo drive. We developed the patent-registered high-speed tracking sensors that provide together with other high-tech components a topmost and dynamic tracking accuracy of a satellite. The TV-system is protected by a UV-stabilized and maritime climate proof radome.

To make an amazing choice of channels available – just like home, we set a high value both on high tracking stability and quality as well as easy handling and maintenance.



Note! The reception of programs in different regions depends on the footprints of the satellites. Also, the TV reception can be affected by rain, snow, dense clouds and extreme movements and there is no warranty for the reception of certain channels.

1.1 EPAK®-TV system overview

Models	Single	Twin	Quattro	Bands EU
TV 43 / TV 44	X	X	-	4
TV 58 / TV 59	X	X	X	4

If you wish to use the respective antenna with one or more receivers, please check the manual from chapter 7.6.2.



1.2 Safety recommendations

1. Please consider the maximum allowable power voltage for the antenna unit. The DC voltage must be between 12 and 36 volts and the overload protection should be rated at min. 5 amp. and max. 7.5 amp..
2. The mounting distance from the antenna unit to other radiation sources, e.g. radar equipment or other transmitting antennas, should be at min. 2.5 m (8 ft).
3. If the satellite antenna is not installed above the radar antenna, simultaneous operation of both systems may damage the satellite antenna.
4. Do not use the control unit outdoors!
5. During a thunderstorm, we recommend to disconnect all connection cables.
6. If the negative side of the antenna unit's supply voltage has no connection to the ship's ground (earth), then the antenna unit's ground point should be connected directly to the ship's ground (earth).
7. After the installation is completed all other electronic systems, i.e. GPS, Radar, VHF, FM, AM etc., should be tested for full functionality while the antenna is turned on.
8. Do not test or turn on the antenna before the radome is fitted correctly. The electronics can be damaged by the reflected sun.
9. Do not touch the rotary joint.
10. Do not open the sealed electronics-box, as this will void the warranty.

2 Installation

2.1 Standard delivery

The satellite tracking system EPAK-TV comes complete with the antenna and the following system components:

- Antenna unit (with serial number)
- Control unit
- Four mounting screws M 8

Please check the completeness of all components. Make sure that no transport damages exist before you start the installation.

2.2 Installation overview

The installation work has to be done in the following order:

- Select location
- Check the mounting surface for stability
- Check cable path
- Position of power distributor
- Drill holes and lay the cable
- Install antenna unit (**see also addendum for instructions of how to undo the fixed transportation position before power-up**)
- Make all installation openings watertight
- Connect cables

For the installation at least the following tools are needed:

- Electric drill
- One 4mm and one 8.5-9 mm drill bits
- Hexagon socket wrench size 6
- 13mm screw wrench

Plan the entire installation first! To avoid mistakes or damages to the boat or satellite tracking system, please read the installation instructions carefully before starting the installation.

2.3 Selecting location

The best location for the TV-antenna is a raised position on your ship. Thus, the needed unobstructed view from the antenna to the satellite with the respective elevation angle can be established. In order not to affect the picture quality or not to damage the antenna, please observe the minimum distance of 8-12ft. (2-3 meters) to the radar equipment and other transmitting antennas! That includes mobile communication units! If there is a radar antenna, the ideal location to mount the antenna will be right above the radar antenna. Please also note that a strong mounting surface is needed and please avoid direct waves and bilge water on the radome. For further details see chapters 2.4 – 2.9.

The following illustration shows the importance of a proper location for the antenna unit.

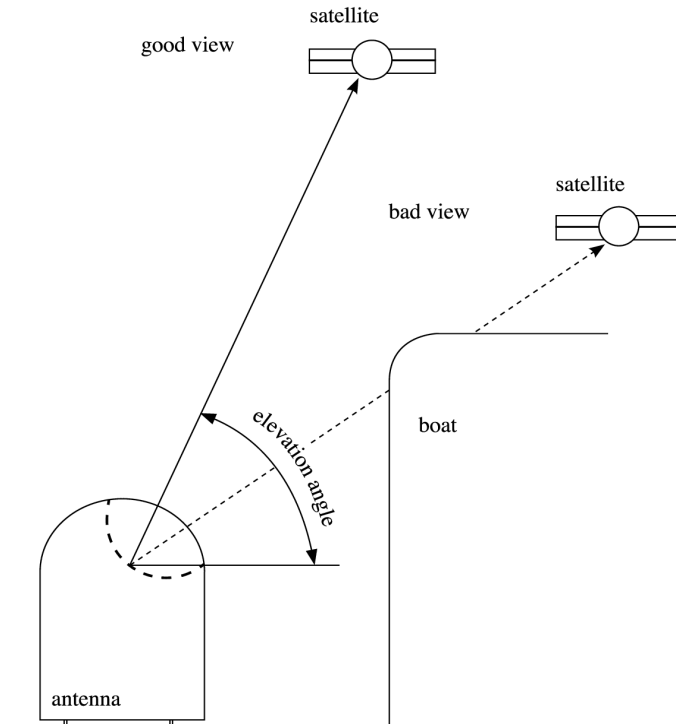

2.4 Mounting surface

A horizontal, solid and steady, and even surface has to be ensured. The weight of the antenna unit is 26.5lbs (12kg) or 35.3lbs (16kg) (depending on the model) and must not be confronted with punctual material stressing.

2.5 Planning the cable paths

Before starting the installation, please check which walls are suitable and if existing openings can be used for the cables.

All openings have to be sealed!

The control unit should be placed as close as possible to the receiver. The cable length should not extend 3 m and the cable must be type 1 (see chapter 7.6.1 for data concerning appropriate cable types).

2.6 Power supply

The antenna unit can be connected directly without a converter to any ship's power supply net of 12/24/32 volts DC. The circuit fuse should be rated for min. 5 amperes and max. 7.5 amperes! (see chapter 7.8 "Technical Specifications").

The power distributor must be idle while working on the ship's supply net or you short circuit the system.

If the negative side of the supply voltage of the antenna unit has no connection to the boat ground, make sure a potential compensation between boat ground and the ground point of the antenna unit is made.

2.7 Drillings

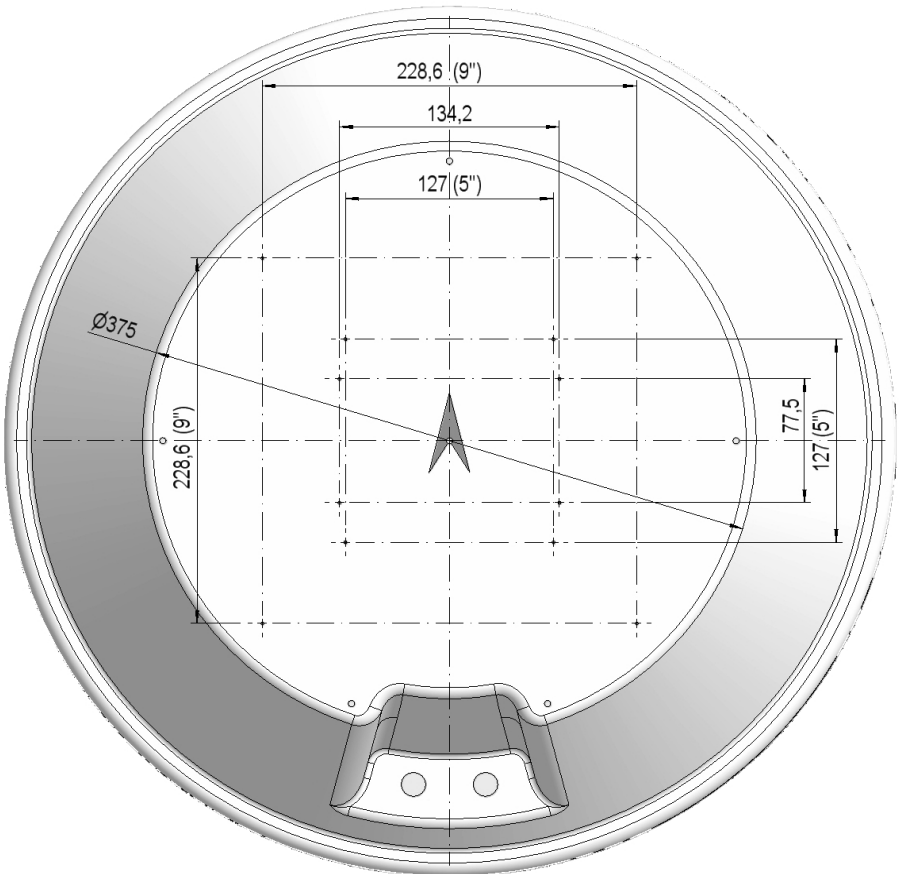

For an ideal mounting of the antenna we prepared 3 different drilling pictures with a diameter of 2 mm in the bottom of the radome. For a good and steady mounting of the antenna we recommend the drilling picture 228.6 mm x 228.6 mm. Please refer to the included template for the drilling measurements (see bottom from below!). The drilling holes have the size of \varnothing 8.5 – 9 mm. We recommend to start with drilling a smaller hole, using a \varnothing 3.5 – 4 mm bit to avoid any damage to the mounting surface. To mount the antenna, only use the included M8 mounting screws!

Possible measurements:

228.6 mm x 228.6 mm, 127.0 mm x 127.0 mm, and 134.2 mm x 77.5 mm

!! If the antenna unit is not mounted on a device carrier or separate mounting plate, close all drilled holes with waterproof sealing material to avoid any water penetrating!

2.8 Mounting the antenna unit

The antenna unit has to be mounted on a solid and steady surface. Take care that the cable lengths are sufficient - the antenna unit must have an unobstructed view to the satellite and that there are no interfering fields (especially mobile communication antennas) nearby. Place the antenna unit on the pre-drilled holes and fasten it with the included screws and washers. The screws have to be screwed in from below through the mounting surface into the radome.

!! Close all drilled holes with waterproof sealing material to avoid any water penetrating!

2.9 System cable connections

!! Break the contact of the circuit on which you are working to avoid a short circuit of the system.

- The antenna cable must be connected to the control unit and the antenna unit, (cable type 1).
- The power supply cable to the power distributor and the antenna unit.
- The receiver cable to the control unit and the receiver, (cable type 1).

!! See system overview and illustration details, chapter 7.6.1 and at the end of the manual.

Lead the cable through the drilled holes and seal it with waterproof sealing material. Furthermore, drip loops should precede the entry point from the exterior to avoid any water penetrating. See illustration below:

WRONG

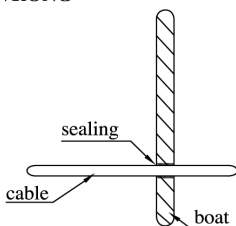

CORRECT

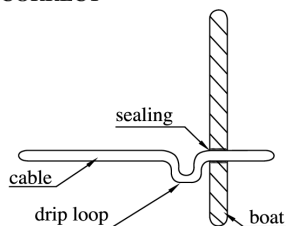

Find a suitable location for all units within cable lengths, meaning the control unit should be placed nearby the receiver. Take care that the display of the control unit can be easily read and the buttons are accessible. Also, allow room for the cables behind the control unit! The antenna unit is separated from the power supply net by the control unit. Therefore, the antenna unit only has electric power when the control unit is turned on!

3 Control elements

3.1 Control unit



The EPAC-TV system is controlled by the control unit. See below a short overview of the key functions:

- **Power key:** Shortly pressed will turn on power or will enter Standby mode.
- ⌚ **Browse key:** Shortly pressed will browse through all available menus and setups or will cancel a current process.
- ✓ **Select key:** Shortly pressed will select/confirm what is written in the display.

Note! From the Standby mode: Press and hold the Select key while using the Browse key to scroll through available data: serial no., counter operation time, and software versions (see chapter 6.3.).

3.2 Preparing the receiver

EPAK-TV does not need a special receiver. The satellite tracking system can be connected to any commercial receiver for digital and analogue reception. Only the LNB-type in the setup menu of the receiver has to be set on "Universal" (LOF 9,75/10,6 GHz). If you want several satellite positions, the DiSEqC™ function for an automatic satellite switch has to be activated.

To program your receiver, please refer to the respective owner's manual!

- !! For every satellite at least one program must be preprogrammed in the receiver to control the satellite position of the antenna unit by means of the TV picture quality. If not, pre-program the receiver by using an already installed satellite system!
- !! In case the receiver supports the function, adjust the receiver so that the power supply of the LNB is turned off during the Standby-mode. This means that the control unit and the antenna unit are without power supply. This function enables the turning on and off of the antenna unit via remote control of the receiver, which lowers the power consumption.
- !! In case several receivers are connected to the antenna simultaneously (e.g. a digital receiver with looped through analogue receiver) both receivers must have identical DiSEqC™ settings, i.e. both active or inactive.

3.3 Power on / off / Standby

The antenna unit is controlled by the control unit. By pressing the \odot (Power) key, the initialization starts. If the antenna was aligned to a stored satellite before the antenna was turned off, it will try to regain that satellite. If the satellite could not be found, the initialization will finish by showing SETUP on the display. Press the Q (Power) key again. You are now in the Standby mode.

!! If the control unit is in Standby mode there will be no power supply to the antenna.

3.4 Password access to Setup menu

To gain access to the Setup menu please enter a password first to avoid a change by accident in the Setup menu. It is always the same password which has to be entered. When `Setup` is flashing in the display:

1. Press \checkmark The display will show: ----
2. Press \odot The display will show: X---
3. Press \checkmark The display will show: XX--
4. Press \odot The display will show: XXX-
5. Press \checkmark The display will show: XXXX

The time between each keystroke should not exceed two seconds or the password request will be annulled. If so, the display will return to a flashing `Setup` and you will have to restart from point 1. If the password is entered correctly, you are now in the Setup menu.

3.5 Adjusting the Setup parameters

Modifications can only be made in the Setup menu. In the main menu only the flashing functions can be selected.

1. Turn on the control unit. The display shows `Init` (flashing), meaning initialization is in progress.
2. After the initialization is completed, you are in the main menu with the display flashing `Setup`. The Setup menu has password access — see chapter 3.4.
3. If the password is entered correctly, you are now in the Setup menu. The display shows `Tracking`, press **✓** to select.
4. Tracking is preset to On. Switch between On and Off with the **↶** key. With Off, tracking is deactivated (see chapter 4.1). With On, tracking is activated i.e. the satellite can be tracked. Press **✓** to select.
5. The display shows `Tracking`. Press **↶** to go to the `FastScan` mode. Press **✓** to select or **↶** to continue from point 7.
6. `FastScan` is preset to On (we do not recommend a change in Europe). Switch between On and Off with the **↶** key (see point 6.4). With On, Fastscan is activated i.e. the search for the correct satellite works faster (US only). Press **✓** to select.
7. The display shows `FastScan`. Press **↶** to go to `LNB Type`. Press **✓** to select.
8. The display will show the standard setting `lin0` which is valid for Europe. By pressing the **↶** key you can change the LNB settings. Press **✓** to select. The display will return to: `LNB Type`.
- !! Please consider that the LNB type is preset to `lin0`. The LNB mounting plate allows a modification of the skew, which can be adjusted to the location. Reception from circular polarized satellites will require a circular LNB type.
9. Press **↶** repeatedly until `CompCal` appears. Press **✓** to select.
- !! The calibration of the compass must be carried out in the harbour in calm waters! If the mounting surface of the antenna unit changes, or if the superstructures in the vicinity of the antenna unit are modified, the calibration has to be done again! See also chapter 6.1.
10. The display interchanges between `Compass` and `Update?`. Press **✓** to calibrate.
11. The display interchanges between `Compass` and `calibrat` and then `checking` until `complete` is shown for a brief moment, and then returns to `CompCal`, which indicates that the calibration of the compass is completed.
12. Press **↶** to go to `Quit`, and press **✓** to confirm.

The system is now adjusted to surrounding conditions and is ready to search for new satellites to be stored.

4 TV operation

Press the **O** key to turn on the control unit. The display shows **Init** for initialization. After the initialization is completed, the display interchanges between **scanning** and **Sat X** (X is the last shown storage position) until the satellite has been located. The system will now run a check on the satellite: **checking** appears on the display. If o.k., the display will briefly show **complete** and then return to **Sat X**. The antenna will maintain its connection to the satellite even when the boat is moving. (Providing that the tracking function is active (**On** in the Setup menu), see chapter 3.5).

If you wish to select a different satellite, press **O** repeatedly until the desired satellite position appears and confirm with **✓**.

!! If no satellites are stored, the display will show **Setup** (flashing). You are now back in the main menu and can add new satellites (see chapter 5.1).

If the search for a new satellite takes more than 1 minute, even though there is a clear view to the satellite, or if, after several times of finding the right satellite, the display shows **UPDREC0** interchanging with the actual satellite number, the satellite data base has to be updated, see chapter 5.2.

If, after the search of the satellite, the display shortly shows (complete) and afterwards (Sat X) without a picture on the TV, there are two possibilities:

1. The satellite service provider has changed the transponders or it is the wrong satellite. In order to proof the right satellite has been found, try to switch to other programs on the receiver. If all other programs are in their usual places, you need to reprogram your receiver for the program which has changed. Please refer to the manual of the receiver.
2. US only: In case no program can be received, try to turn off the Fastscan function (see chapter 6.4).

When changes are made, return to **Sat X** and press **✓** to start a new search. If the search for a new satellite takes longer than 4 minutes and after some time the display shows **Sat ok?**, then the requested satellite could not be found. All available satellites will be presented and the operator can choose one.

Make sure the receiver is switched to a program from the requested satellite, so the correct satellite can be identified.

If the display shows **Sat ok?** and there is no picture on the TV, press **O** to continue the search. This has to be repeated until the TV shows the correct picture. Press **✓** to confirm. The display will now interchange between **Sat X** and **Update?**. Press **✓** to update the satellite data base. The display will flash: **updating**, and shortly after: **checking**, and then: **complete**. The display will now return to **Sat X** and the requested program will appear on the TV. If the display interchanges between **scanning** and **complete** during the search, no suitable satellite could be found.

After confirming with **✓** you are back in the main menu and the display will show **Setup** (flashing). Check all cable connections and make sure there is a clear view (no obstacles) to the satellite and the receiver is correctly adjusted. Then repeat this procedure.

!! The menu item **Upd Sat** is not shown when the tracking function is deactivated (see

chapter 4.1).

Should the antenna lose the signal from the satellite (due to a passing boat, buildings on shore, bridges, or superstructures on own boat), the display will interchange between `Sat X` (stored position of current satellite) and `no Sig` for the duration of the missing satellite reception.

The tracking mode will automatically restart if the satellite signal could not be found within 30 seconds. The display interchanges between `scanning` and `Sat X`. In case superstructures obstruct the view to the satellite, turn the vessel or the satellite cannot be found!

!! To select a stored satellite, refer to chapter 5.4.

4.1 Stopping the Tracking function in harbours

If the boat is in a harbour, the tracking function can be deactivated to stop the tracking (noise-reduction). Proceed as follows:

1. Press `O` repeatedly until the display flashes. You are in the main menu.
2. To go to the Setup menu, press `O` repeatedly until the display shows `Setup` (flashing), then press `✓`. Enter password, see chapter 3.4. If the password is correct you are in the Setup menu with `Tracking` on the display.
3. Press `✓` to select, and press `O` to switch between ON and OFF. The tracking function must be in OFF position to be deactivated. Confirm with `✓`.
4. The display returns to `Tracking`. Press `O` repeatedly until the display shows `Quit`. Confirm with `✓`. The display returns to: `Setup`.

You are now back in the main menu and can switch to other satellites or make adjustments in the Setup menu.

!! When the tracking function is deactivated, the antenna does not track the satellite, so it is possible that the TV picture sometimes can deteriorate or drop out. A realignment with the satellite is always possible: Press `O` repeatedly until the display shows a flashing `Sat X` (whereas X is the respective number of the selected satellite). Confirm with `✓`.

5 Satellites

5.1 Adding new satellites

The search and storage of new satellites on the ship must be done in the harbour in calm waters! For every satellite at least one program must be preprogrammed in the receiver to control the satellite position of the antenna unit by means of the TV picture quality. Make sure the preprogrammed TV station for the desired satellite is turned on at the receiver, as the system stops at each receivable satellite. The satellite can be identified by the quality of the TV picture.

Please proceed as follows:

1. To go to the Setup menu, press **⏪** repeatedly until the display shows **Setup** (flashing), then press **✓**. Enter password, see chapter 3.4. If the password is correct you are in the Setup menu with the display showing: **Tracking**.
 2. Press **⏪** repeatedly until **New Sat** appears on the display. Press **✓** to select. For two seconds **Search?** appears and changes to **Sat X**.
You have now the possibility to choose between **band-tracking** and **channel-tracking**. The advantage of the channel-tracking mode is the selection of the measurement frequency. By this method external interfering radiation can be prevented. The band-tracking mode can achieve a better tracking result.
We recommend the channel-tracking mode. With the **⏪** key you will automatically get into the channel-mode. By repeatedly pressing the **⏪** key you can choose the desired stored satellite. Confirm with **✓**.
If you chose band-tracking, please confirm **Sat X** by pressing **✓**.
- !!** **New Sat** only appears in the display, if free satellite storage positions are available. In case all storage positions are occupied, the less required ones have to be deleted first. (see chapter 5.3).
3. If you chose **Sat X**, **ScnBand** will be shown for 2 seconds. After that, use the **⏪** key to change band between **Band1** and **Band4** to select the band in which the satellite should be searched. Please refer to the band numbers in the following table:

Band 1	10700 MHz	11700 MHz	Polarization vertical	(vertical low / VL)
Band 2	10700 MHz	11700 MHz	Polarization horizontal	(horizontal low / HL)
Band 3	11700 MHz	12750 MHz	Polarization vertical	(vertical high / VH)
Band 4	11700 MHz	12750 MHz	Polarization horizontal	(horizontal high / HH)

Example

Astra 2	Band 3
Hotbird	Band 3
Sirius	Band 3
US	Band 2

4. Confirm with **✓** or cancel with **⏪**.

5. You can see `COMPASS` for two seconds. `ON` is given as standard. With `⓪` you can choose `OFF` and switch off the compass. Please confirm your choice by pressing `✓`. (Also see chapter 6.1)
 6. The display interchanges between `New Sat` and `Search?`.
 7. Confirm with `✓`, or cancel with `⓪`.
 8. In case you canceled the process, the display will briefly show `cancel` and then return to the Setup menu showing `New Sat` (see point 2!). If you confirmed, the search mode is activated and the display shows `scanning` (flashing). The search mode can be interrupted at any time by pressing `⓪`, which brings you back to the main menu. The display shows `Setup` (flashing).
 9. If the tracking system has scanned the whole area without locating a satellite, the display shows `scanning` interchanging with `complete`. Confirm with `✓`. You are back in the main menu with `Setup` flashing. Before restarting the search mode (see point 1), check if there is a clear view to the satellite, if the program selected on the receiver is o.k. (possibly change to another program) and if the respective satellite can be received in this area! If no satellite is found, repeat the search in another band (see point 3).
 - !! Before you restart the search-mode, make sure that no superstructures obstruct the view to the satellite!
 10. The search-mode stops after a satellite is found. The display shows `Sat ok?` (flashing). Check the quality of the TV picture! In case there is no picture or the wrong TV program, proceed with the search-mode by pressing `⓪` repeatedly until the correct TV program is found. Press `✓` to confirm.
 11. The display shows `Save as?` just for a brief moment.
 12. A list of the different storage positions is shown. Use the `⓪` key to choose between `Sat 1` and `Sat 4`, confirm with `✓`.
- Note!** If you want to use the Auto-Sat function (see chapter 5.4.1), please consider that only free storage positions are shown. Every receiver supporting the DiSEqC™ function allocates the satellite positions to one of the DiSEqC™ positions 1 – 4. Therefore, make sure that all satellites in the DiSEqC™ menu of the receiver and of the antenna unit are stored under the same number! This allows the use of the Auto Sat function (see chapter 5.4.2).
- !! Example: Satellite Astra is stored under DiSEqC™ position 2 in the receiver, meaning that this satellite has to be stored in the antenna unit under Sat 2! Receivers which do not support the DiSEqC™ function will allow any order of numbers. Press `✓`.
 13. The display interchanges between a flashing `Sat X` and `save?`, whereas X is the previously chosen storage position. Confirm with `✓`. (continue with point 14)
If you want to cancel the function, press `⓪`, which interrupts the storage. The display will briefly show `cancel` and then return to `Sat ok?`. You may now continue the search, or you can store the satellite just received at another storage position. (see point 4).
 14. If you chose to confirm in point 13, the display shows `saving..` (flashing) for appr. 1 minute. The data of the satellite is now automatically memorized and stored. The display briefly shows: `checking`.
 - !! While the data is being stored, the ship must not move, a permanent clear view to the satellite must be guaranteed, and the antenna unit must not be turned off!
 15. When the data is memorized, the display shows `complete` for a brief moment and

then the system automatically jumps to the TV mode of the just stored satellite (the display shows `Sat X`, whereas X is the storage position). The ship can now be moved and the reception tested. In case a failure occurs and the data is not memorized correctly, the display shows `ErrSave` and the calibration has to be done again.

!! For each new satellite, the search-mode must be repeated! You can store up to four satellites.

5.2 Update of satellite data base

Example : The Astra satellite was stored in German waters. Now the vessel is sailing in Scandinavian waters. The angles of the satellite has, therefore, moved and it takes longer to locate the satellite. To shorten the search time, new data for the angles has to be stored:

1. To go to the Setup menu, press `○` repeatedly until the display shows `Setup` (flashing), then press `✓`. Enter password, see chapter 3.4. If the password is correct you are in the Setup menu.
2. Press `○` repeatedly until `UpdSat` appears. Now the up-to-date angles can be stored by pressing `✓`. Please keep in mind, that the menu item `UpdSat` is not shown, if the tracking function is deactivated (see chapter 4.1).
3. The display interchanges between `Sat X` (storage position of current satellite) and `Update`.
4. To cancel, press `○` / to confirm (if the picture quality is optimal), press `✓`.
5. If you chose to cancel, the display shows **cancel(format)** for a brief moment. If you chose confirm, the display interchanges between `updating` and `checking`.
6. After correct calibration, the display shows **complete(format)** for a brief moment and the system automatically jumps to the TV mode. If the update was not successful the display shows `ErrSave` and the system returns to the menu item `UpdSat`. In this case, please repeat the calibration.

Next time the antenna is turned on, the angles and frequency data of the satellite are stored for the current area. This procedure should be repeated in every other region (at a distance of 200-300 km), because the angles of the satellite move with every change of the vessel's position.

5.3 Delete stored data

To delete stored satellite positions, the following steps must be completed:

1. To go to the Setup menu: press `○` repeatedly until the display shows `Setup` (flashing), then press `✓`. Enter password, see chapter 3.4. If the password is correct you are in the Setup menu.
 2. The display now shows `Tracking`. Press `○` repeatedly until `Del Sat` appears. Press `✓`.
- !! `Del Sat` can only appears if satellites are stored in the system.
3. The display shows `Sat X`, whereas X is the first satellite storage position to be deleted. To choose the satellite to be deleted, press `○` and confirm with `✓`.
 4. The display interchanges between `Sat X` and `Delete`. To confirm, press `✓` / to cancel, press `○`.
 5. If you chose confirm the display shows `complete` for a brief moment. If you chose

cancel, the display shows `cancel`.

6. In both cases, the display will return to `Del Sat`.

!! If no further satellites are available for deletion, the display shows `Tracking!`

If there are more satellites in the system you wish to delete, press `✓` and repeat from point 3! If you want to leave the menu, press `⏪` until `Quit` appears and then press `✓`. The display shows `Setup` (flashing).

You are now back in the main menu and can switch to other satellites or make adjustments in the Setup menu by pressing the `⏪` key.

5.4 Selection of stored satellites

5.4.1 Automatic selection of satellites

For an automatic selection of satellites, the receiver must support the DiSEqC™ function. Furthermore, it is important that all satellites in the DiSEqC™ menu of the receiver and of the antenna unit are stored **under the same number!** In case your receiver does not support DiSEqC™ please go to chapter 5.4.2.

!! **Example:** Satellite Astra is stored under DiSEqC™ position 2 in the receiver, meaning that this satellite has to be stored in the antenna unit under `Sat 2`.

1. Press `⏪` repeatedly until the display shows `Auto Sat` (flashing). Press `✓`. From now on, the antenna unit will take over the satellite positions from the receiver. The display interchanges between `scanning` and `Sat X`, whereas X is the desired storing position. After the satellite is located, the display will continue to show `Sat X`. The satellite tracking system is now in TV mode.

!! If `Auto Sat` does not appear in the display, the feature is not supported by the receiver (or not activated). The setting is DiSEqC 1.4 or similar. Refer to the user manual of the receiver. The TV45 does not support this feature.

If the selected satellite is not stored in the antenna unit, the display interchanges between `Sat X` (the selected storage position) and `noData`. In this case, check the receiver parameters and store the satellite in the antenna unit, meaning that the search mode has to be started again (see chapter 4).

You can now switch to the main menu (flashing display) by pressing the `⏪` key.

5.4.2 Manual selection of satellites

For a manual selection of satellites, see the following procedure:

1. Press `⏪` repeatedly until the display shows flashing `Sat X`, whereas X is the satellite storage position.
2. Select between the storage positions 1 - 4 by pressing `⏪`. Confirm with `✓`.

!! Only satellites already stored are shown.

The display interchanges between `scanning` and `Sat X`, whereas X is the desired storage position. After the satellite is found, the display will continue to show X. The satellite tracking system is now in TV mode.

6 Miscellaneous

6.1 Compass calibration

The calibration of the compass has to be executed in the harbour in calm waters! If the mounting surface of the antenna unit changes, or if the superstructures in vicinity of the antenna unit are modified, the calibration has to be done again!

Please proceed as follows:

1. To go to the Setup menu, press **0** repeatedly until the display shows **Setup** (flashing), then press **✓**. Enter password, see chapter 3.4. If the password is correct you are in the Setup menu with **Tracking** on the display.
 2. Press **0** repeatedly until **CompCal** appears. Press **✓** to confirm.
 3. The display interchanges between **Compass** and **Update?**. Press **✓** to calibrate.
 4. The display interchanges between **Compass** and **calibrat** and then **checking** (flashing). If the calibration was successful, **complete** is shown for a brief moment.. After that it returns to **CompCal**. If the display shows **ErrComp**, the calibration was not successful and has to be repeated. If several attempts remain unsuccessful, there are too many ferromagnetic objects close by the antenna causing electromagnetic disturbances.
- !! Should these objects not be displaceable, please turn off the compass for that desired satellite position. (see chapter 5.1.5)
5. The display will return to **CompCal**. Press **0** to go to **quit**, and press **✓** to confirm. The display shows **Setup** (flashing).

You are now back in the main menu and can switch to other satellites or make adjustments in the Setup menu by pressing the **0** key.

6.2 Adjustment of the LNB type

In order to change the LNB type, see the following procedure:

1. To go to the Setup menu, press **0** repeatedly until the display shows **Setup** (flashing), then press **✓**. Enter password, see chapter 3.4. If the password is correct you are in the Setup menu with **Tracking** on the display.
 2. Press **0** repeatedly until **LNB Type** appears. Press **✓** to confirm.
 3. The display will show **lin 0(format)**, the standard setting valid for Europe for a linear LNB with a skew of 0°. By pressing the **0** key you can change the LNB settings. Press **✓** to confirm. The display will return to: **LNB Type**.
- !! The standard setting **lin 0** is supported by a standard system (see chapter 3.5) The LNB mounting plate makes a change of the skew possible. Please adjust the skew to the respective location. Reception from circular polarized satellites will require a circular LNB type.
4. Press **0** repeatedly until **quit** appears, then press **✓**. The display shows **Setup** (flashing).

You are now back in the main menu and can switch to other satellites or make adjustments in the Setup menu by pressing the **⏏** key.

6.3 Special functions via the Standby mode

The following information can be obtained via the Standby mode: software version of antenna unit and control unit, serial number and operating hours counter.

Please proceed as follows:

1. Turn on the control unit. The display shows `Init`, meaning initialization is started. Wait for the initialization to be completed, and then press the **⏏** key to enter the Standby mode.
2. To obtain the special functions, press and hold the **✓** key while switching between the following functions with the **⏏** key:
 - " serial number.
 - " operating hours counter.
 - " software version of the antenna unit: `UA X-XX`
 - " software version of the control unit: `UC X-XX`
3. After releasing the **✓** key, the display returns to `Standby`.

6.4 Fastscan function (US only)

The tracking system works faster with the Fastscan function. However, if the antenna is locked to a satellite and the TV does not show a picture, the Fastscan function can be deactivated by following these steps:

1. Press **⏏** repeatedly until the display shows `Setup` (flashing), then press **✓**. Enter password, see chapter 3.4. If the password is correct you are in the Setup menu with `Tracking` on the display.
2. Press **⏏** repeatedly until `FastScan` appears. Press **✓** to confirm.
3. Press **⏏** to switch from On to Off, and confirm with **✓**.
4. The display now returns to `FastScan`. Press **⏏** until `quit` appears and confirm with **✓**. The display shows `Setup` (flashing).

You are now back in the main menu and can switch to other satellites or make adjustments in the Setup menu by pressing the **⏏** key.

7 APPENDICES

7.1 Maintenance

The satellite tracking system EPAK-TV is easy to maintain. The following instructions are sufficient to sustain an optimal capacity of the antenna unit:

- Clean the radome once a month using fresh water and a mild detergent to remove dirt and salt deposits.
 - Do not detach the radome!
 - Do not spray directly on the radome with high pressure water from a hose!
 - Check cable connections to be tight and free of corrosion. Clean the cables regularly.
- !! The radome has a protective layer of UV-stabilized and maritime climate-proof lacquer. Do not apply any additional paint, wax, preservative, solvent, chemicals, or adhesive labels. Do not use alcohol or dilution or similar products to clean the radome. Any kind of coating will void warranty claims! In case any solvent comes in contact with the radome by accident, rinse the area immediately with water and, if necessary, with a mild detergent!
- !! A guarantee for UV and colour stability as well as fracture strength can only be given within the warranty of the supplier / dealer.

Footnotes of chapter 7.2

- 1) Always possible, as long as free satellite storage positions are available.
- 2) Only shown in the display if the respective satellite storage position is occupied.
- 3) Only the occupied satellite storage positions are shown.
- 4) Confirm function by pressing ✓, cancel by pressing ⌫.
- 5) Function has to be carried out in the harbour in calm waters.
- 6) Standby mode can be reached from all menu items by shortly pressing the ⏻ key.
- 7) Display flashes (New Sat / Search?) .
- 8) Only, if at least one satellite is stored and the receiver supports this feature (DiSEqC™).
- 9) Special functions in standby mode.

7.2 Overview of menu structure

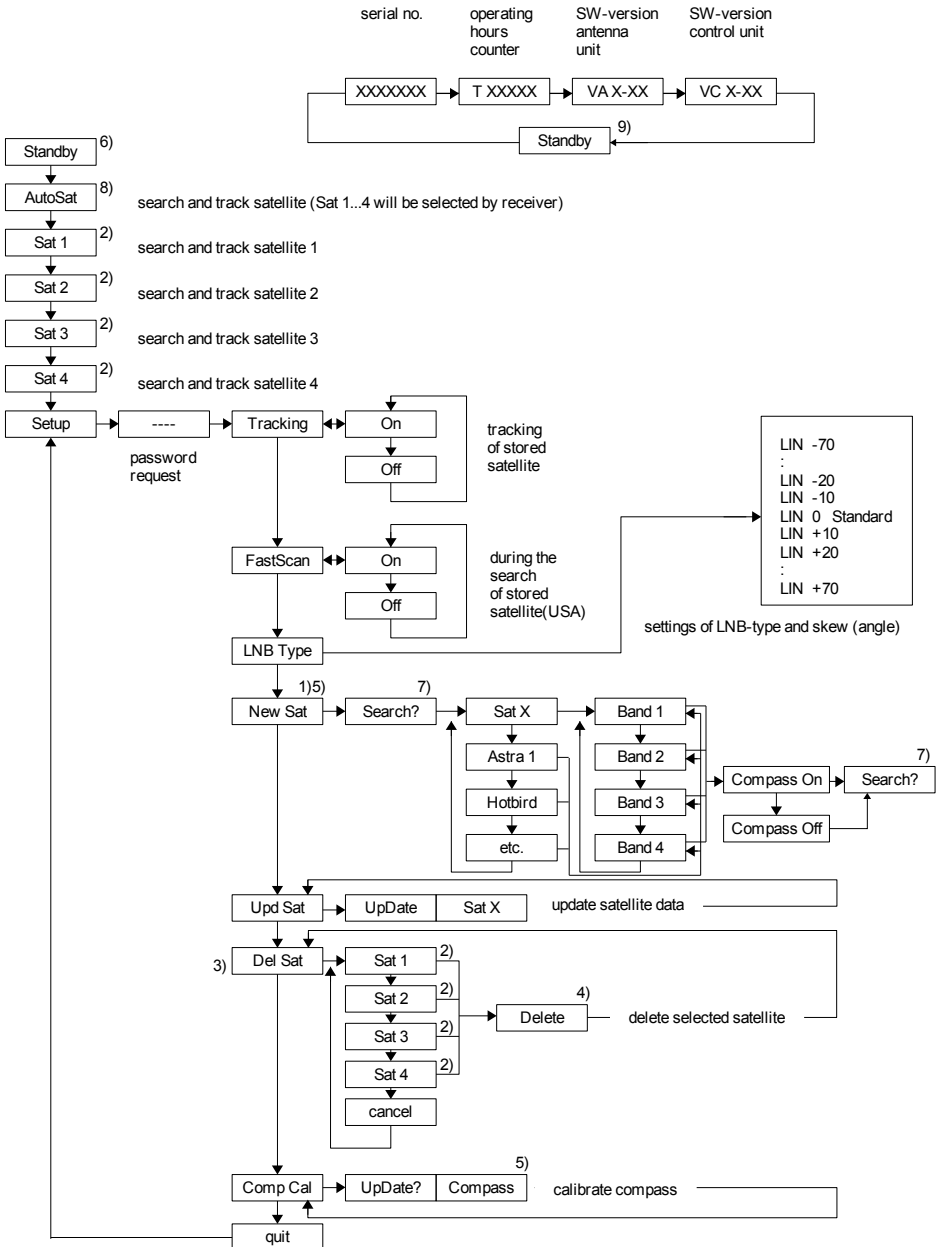

7.3 Fehlermeldungen

Display	Problem	Remedy
no dish	No connection to the antenna unit	- Check cable connection to antenna unit (power and antenna cable) - Check antenna unit's power supply
ErrorCom	Communication error with antenna unit	Turn unit off and after 3 seconds on again
Low Batt	Power supply too low (<11.5V)	- Check power supply connection for antenna unit (loose cable, etc.) - Charge battery
no Data	The satellite position requested by the receiver in AutoSat mode is not stored in antenna unit	- Check the DiSEqC™ adjustment of the receiver - Add satellite and store position (see chapter 5.1).
Err HR	Read error of horizontal unit	- Turn the unit off and on again. In case the error reoccurs, call for technical assistance.
Err HW	Write error of horizontal unit	see error Err HR
Err VR	Read error of vertical unit	see error Err HR
Err VW	Write error of vertical unit	see error Err HR
Err SR	Read error of signal processing unit	see error Err HR
Err SW	write error of signal processing unit	see error Err HR
Err EEP	Error during storage	see error Err HR
Err IIC	Error in internal communication	see error Err HR
Err Trck	Error in tracking module	see error Err HR
Err ULS	Error in upper limit switch	see error Err HR
Err LLS	Error in lower limit switch	see error Err HR
Err COMP	Compass error	- Compass will automatically reset and re-calibrate. (In case the error

Display	Problem	Remedy
		reoccurs several times, call for technical assistance.)
Err Save	Error while saving satellite	Repeat search and storing procedure. Make sure the boat is not moving and no superstructures obstruct the sight to the satellite
complete	The search for a stored satellite was successful, but no picture is shown	<ul style="list-style-type: none"> - Deactivate Fastscan mode - Delete satellite storage positions and memorize again
Sat X interchanging with no Sig	No reception of the stored satellite	<ul style="list-style-type: none"> - Check if superstructures (e.g. steeple cab) obstruct the sight to the satellite - if so, move the boat about 3° - Reception can be briefly interrupted by passing boats
scanning interchanging with complete	No receivable satellite in the entire search range	<ul style="list-style-type: none"> - Select other program on the receiver and search again. - Check, if any superstructures are obstructing the sight to the satellite - Check, by using footprint cards (e.g. www.satcodx.com), that the boat is inside the coverage area (footprint)
	Cannot find a satellite	- Check, if superstructures obstruct the view to the satellite, and restart the search mode
	Cannot find a stored satellite	<ul style="list-style-type: none"> - Check, if superstructures obstruct the view to the satellite - Delete the stored satellite and restart the search mode
	Search for stored satellite takes longer, even though there are no obstructions in the view to the satellite	- Modify angles of the satellite at the new location with the function <code>Upd Sat</code> , see chapter 5.2.

7.4 Replaceable parts

- Electronic box
- LNB, matrix board
- Sensor and limit switch unit
- Control unit

7.5 Optional parts

Multi users kit, amplifier, splitter, etc.

All parts are available at your local authorized dealer/installer.

!! Unauthorized attempts made to open the radome will void any warranty claims!

7.6 System overview

7.6.1 General cable data

Type 1 Double shielded satellite coax cable (75 Ohms) with F-connectors (one-wire).

Type 2 Double shielded satellite coax cable (75 Ohms) with F-connectors (five-wire in one coating).

Type 3 AV cable or Antenna cable (depends on user's installation).

Type 4 Power cable (min. 2 x 1.5sqmm), max. length 15m.

7.6.2 Single User on Single EU Antenna

One receiver has unlimited access to all channels of all 4 bands. It can switch antenna on/off as well as select another satellite.

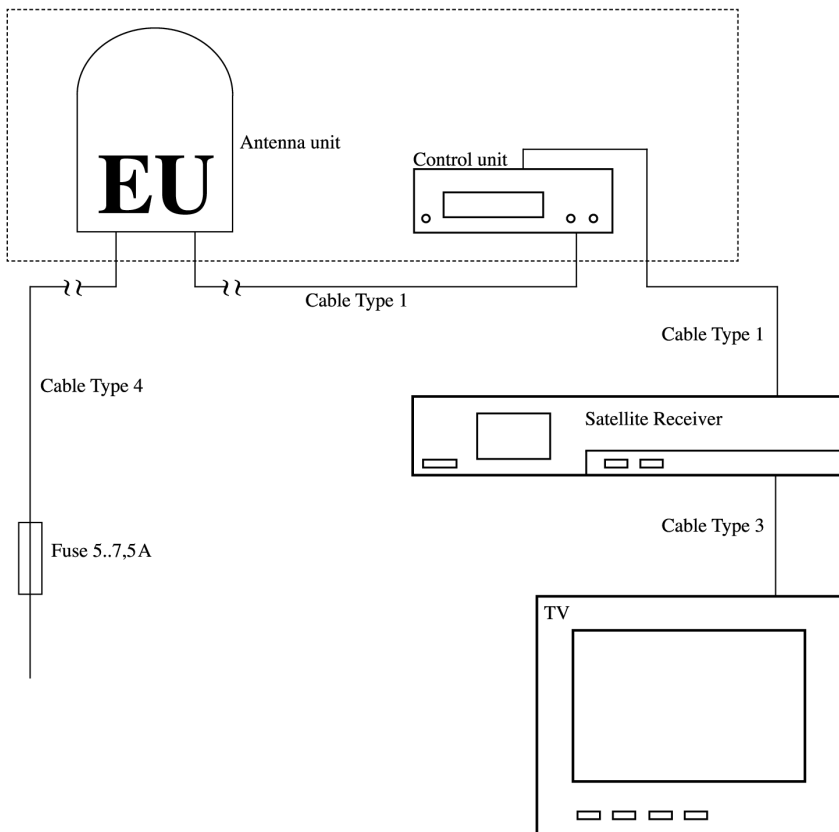

7.6.3 Multi Users on Single EU Antenna

The master receiver has complete access to all channels of all 4 bands. It can switch the antenna on/off as well as select another satellite. All slave receivers have access to all TV channels from the band at the satellite selected by the master receiver. (see chapter 7.6.2).

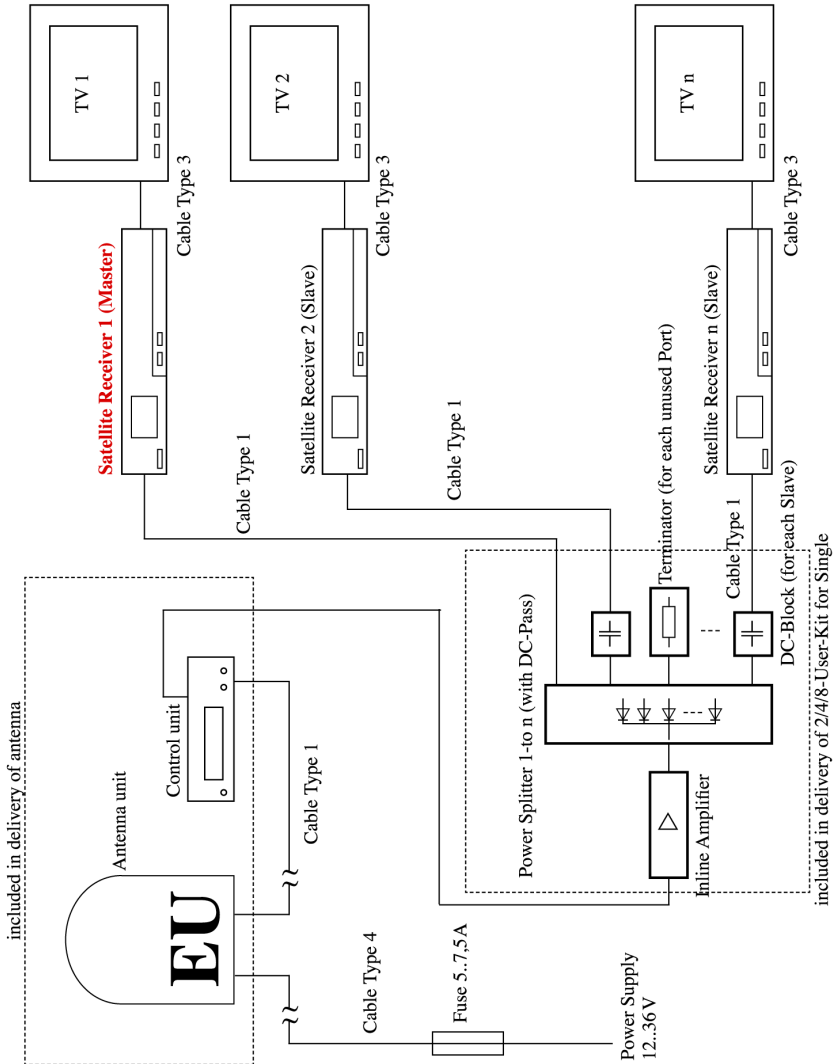

7.6.4 Two Users on Twin EU Antenna

Both receivers work independently and have complete access to all TV channels from all 4 bands. Both can switch the antenna on/off. Only the master receiver can select another satellite. (see chapter 7.6.2).

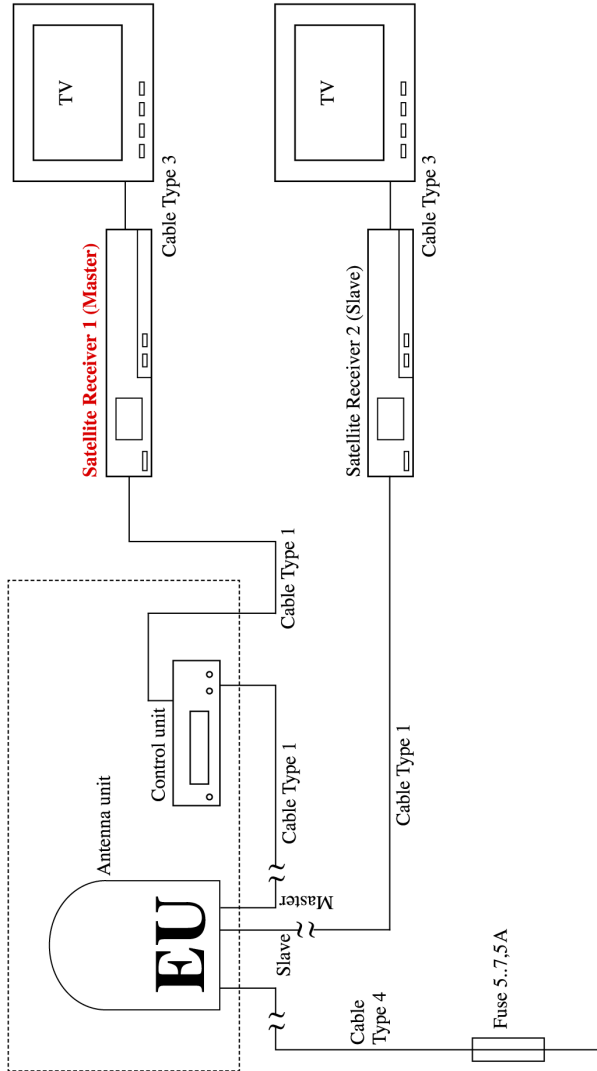

7.6.5 Multi Users on Twin EU Antenna

All receivers work independently and have complete access to all TV channels from two of the four bands. They can switch the antenna on/off. Only the Control Unit can select another satellite. (see chapter 7.6.2).

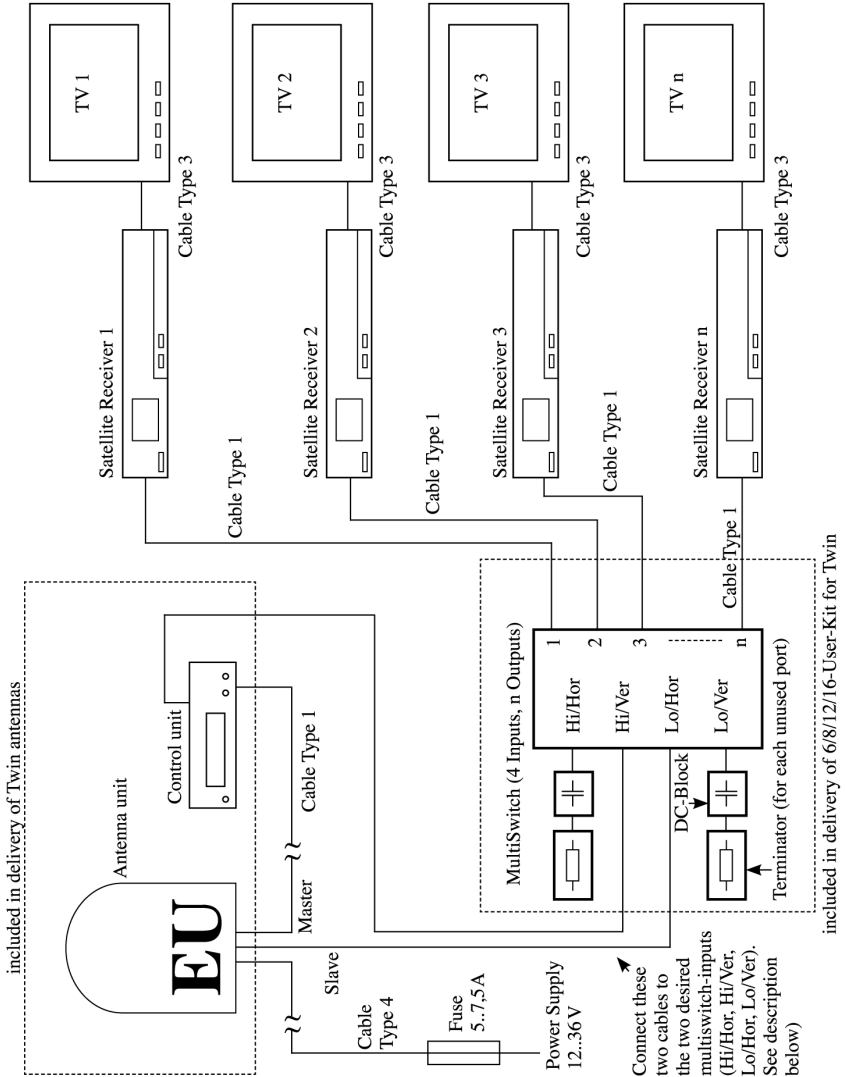

7.6.6 Multi Users on Quattro EU Antenna

All receivers work independently and have complete access to all TV channels of all 4 bands. They can switch the antenna on/off. Only the Control Unit can select another satellite. (see chapter 7.6.2).

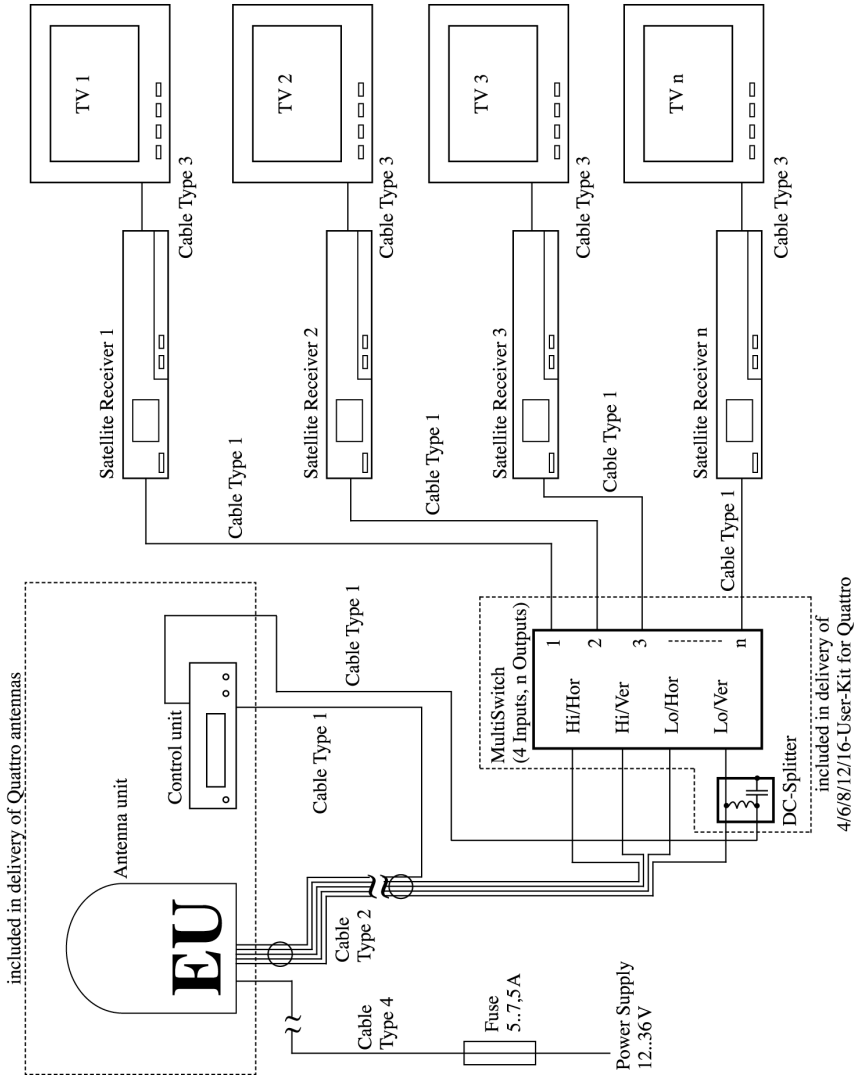

7.7 Elevation angles

Area	Sirius (5°E)	Hotbird (13°E)	Astra (19°E)	Turksat (42°E)
Antalya	39°	43°	45°	47°
Athens	41°	44°	45°	45°
Balaton	31°	34°	35°	36°
Barcelona	42°	40°	39°	33°
Batumi	28°	39°	36°	40°
Berlin	29°	30°	30°	24°
Bordeaux	38°	33°	34°	29°
Bornholm	26°	36°	27°	25°
Burgas	36°	27°	40°	40°
Constanta	34°	37°	39°	39°
Copenhagen	26°	26°	26°	24°
Cork	28°	26°	24°	19°
Corsika	41°	41°	40°	36°
Crete	45°	48°	49°	49°
Crimera	30°	34°	36°	38°
Cyprus	40°	45°	47°	50°
Düsseldorf	31°	31°	30°	23°
Edinburgh	25°	24°	23°	19°
Gdansk	26°	27°	28°	26°
Gibraltar	46°	43°	40°	33°
Hamburg	29°	29°	28°	22°
Helsinki	19°	21°	21°	21°
Istanbul	36°	39°	41°	42°

Area	Sirius (5°E)	Hotbird (13°E)	Astra (19°E)	Turksat (42°E)
Kiel	27°	27°	27°	25°
Leipzig	30°	31°	31°	25°
Lisbon	42°	39°	36°	28°
Majorca	44°	43°	41°	35°
Malta	47°	48°	48°	44°
Marseilles	40°	39°	38°	33°
Munich	34°	35°	34°	27°
Naples	42°	43°	42°	39°
Palermo	45°	45	45°	41°
Plymouth	29°	28°	26°	21°
Rhodes	41°	45°	47°	48°
Riga	24°	26°	27°	26°
Rome	41°	41°	41°	38°
Rotterdam	30°	30°	30°	25°
Sardinia	43°	43°	42°	38°
Split	35°	38°	39°	40°
Stockholm	21°	22°	22°	21°
Stuttgart	34°	34°	33°	26°
Thessaloniki	39°	41°	42°	41°
Trondheim	18°	18°	18°	16°
Venice	37°	37°	37°	34°
Wilhelmshaven	28°	28°	27°	25°

7.8 Technical specifications

Antenna unit	TV 43 / TV 44	TV 58 / TV 59
Reflector Type	Prime Focus	Prime Focus
Reflector Diameter	45 cm (17.7")	60 cm (23.6")
Reflector Gain	33 dB	34.8 dB
Minimum E.I.R.P.* (for reception of geostationary satellites)	49 dBW	48 dBW
LNB (EU)	H/V linear, universal	H/V linear, universal
LNB (US)	LH/RH circular	LH/RH circular
Radome diameter	550 mm	710 mm
Radome height	550 mm	690 mm
Weight (incl. radome)	12 kg	16 kg
Azimuth range	unlimited	unlimited
Elevation range	5-85°	5-90°
Step width	0.1°	0.1°
Drive system	two-axis servo system	two-axis servo system
Tracking sensor	Electronic Beam Forming (EBF)	Electronic Beam Forming (EBF)
Tracking speed (at every movement of ship)	>12°/s / >40°/s	>12°/s / >40°/s
Power supply	12 bis 36VDC, 10 to 20W	12 bis 36VDC, 10 to 20W
Power on satellite lock time	10 to 20 s	10 to 20 s

System	TV 43 / TV 44	TV 58 / TV 59
Operation temperature	20 to +70°C	20 to +70°C
Storing temperature	30 to +85°C	30 to +85°C

Control unit	TV 43 / TV 44 / TV 58 / TV 59
Power supply	12 to 20VDC, 100mA (via coax cable)
Satellite acquisition	fully automatically by SatFingerprint Technology
Satellite storage position	4 (20 selected satellites deposited)
Selection of deposited satellites	control unit / receiver (via DiSEqC" 1.0 or MiniDiSEqC" / Tone-Burst)

Please note that our antennas are subject to a permanent upgrade. Therefore, divergences to the present document may occur.